

TEAC

CX-225iDAB

Micro Hi-Fi System OWNER'S MANUAL

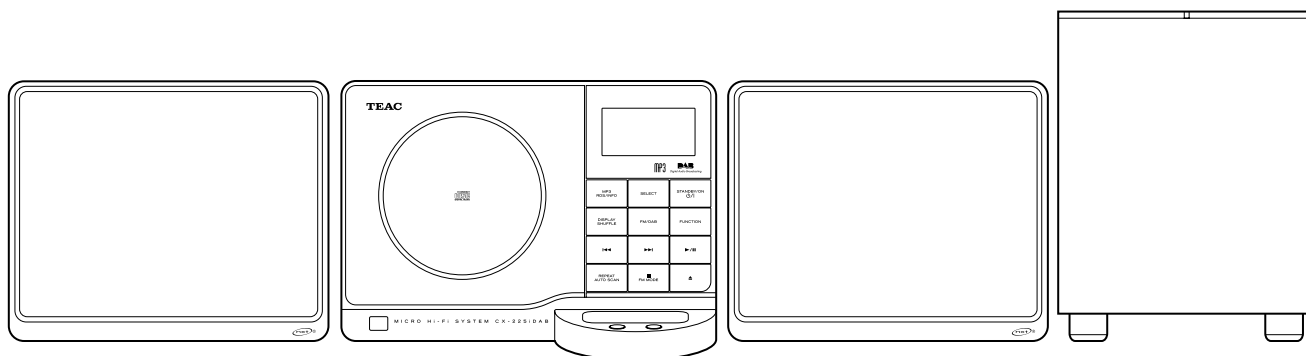

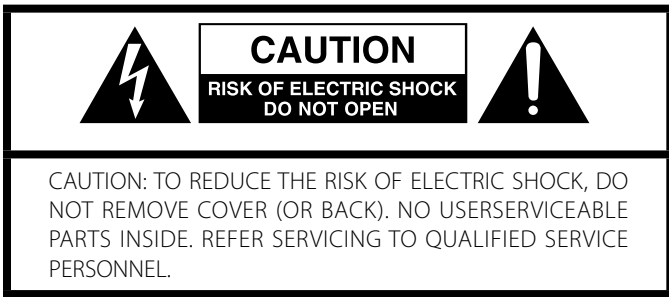

The lightning flash with arrowhead symbol, within an equilateral triangle, is intended to alert the user to the presence of uninsulated "dangerous voltage" within the product's enclosure that may be of sufficient magnitude to constitute a risk of electric shock to persons.



The exclamation point within an equilateral triangle is intended to alert the user to the presence of important operating and maintenance (servicing) instructions in the literature accompanying the appliance.

IMPORTANT SAFETY INSTRUCTIONS

- 1) Read these instructions.
- 2) Keep these instructions.
- 3) Heed all warnings.
- 4) Follow all instructions.
- 5) Do not use this apparatus near water.
- 6) Clean only with dry cloth.
- 7) Do not block any ventilation openings. Install in accordance with the manufacturer's instructions.
- 8) Do not install near any heat sources such as radiators, heat registers, stoves, or other apparatus (including amplifiers) that produce heat.
- 9) Do not defeat the safety purpose of the polarized or grounding-type plug. A polarized plug has two blades with one wider than the other. A grounding type plug has two blades and a third grounding prong. The wide blade or the third prong are provided for your safety. If the provided plug does not fit into your outlet, consult an electrician for replacement of the obsolete outlet.
- 10) Protect the power cord from being walked on or pinched particularly at plugs, convenience receptacles, and the point where they exit from the apparatus.
- 11) Only use attachments/accessories specified by the manufacturer.
- 12) Use only with the cart, stand, tripod, bracket, or table specified by the manufacturer, or sold with the apparatus. When a cart is used, use caution when moving the cart/apparatus combination to avoid injury from tip-over.
- 13) Unplug this apparatus during lightning storms or when unused for long periods of time.
- 14) Refer all servicing to qualified service personnel. Servicing is required when the apparatus has been damaged in any way, such as power-supply cord or plug is damaged, liquid has been spilled or objects have fallen into the apparatus, the apparatus has been exposed to rain or moisture, does not operate normally, or has been dropped.



- Do not expose this apparatus to drips or splashes.
- Do not place any objects filled with liquids, such as vases, on the apparatus.
- Do not install this apparatus in a confined space such as a book case or similar unit.
- The apparatus draws nominal non-operating power from the AC outlet with its POWER switch in the off position.
- The apparatus should be located close enough to the AC outlet so that you can easily grasp the power cord plug at any time.
- An apparatus with Class **I** construction shall be connected to an AC outlet with a protective grounding connection.
- Batteries (battery pack or batteries installed) shall not be exposed to excessive heat such as sunshine, fire or the like.
- Excessive sound pressure from earphones and headphones can cause hearing loss.
- The main plug is used as the disconnect device, the disconnect device shall remain readily operable.

WARNING: TO PREVENT FIRE OR SHOCK HAZARD, DO NOT EXPOSE THIS APPLIANCE TO RAIN OR MOISTURE.

CAUTION

- DO NOT REMOVE THE EXTERNAL CASES OR CABINETS TO EXPOSE THE ELECTRONICS. NO USER SERVICEABLE PARTS ARE WITHIN!
- IF YOU ARE EXPERIENCING PROBLEMS WITH THIS PRODUCT, CONTACT TEAC FOR A SERVICE REFERRAL. DO NOT USE THE PRODUCT UNTIL IT HAS BEEN REPAIRED.
- USE OF CONTROLS OR ADJUSTMENTS OR PERFORMANCE OF PROCEDURES OTHER THAN THOSE SPECIFIED HEREIN MAY RESULT IN HAZARDOUS RADIATION EXPOSURE.

Contents

Thank you for choosing TEAC. Read this manual carefully to get the best performance from this unit.

IMPORTANT SAFETY INSTRUCTIONS.....	2
Contents	3
Before Using the Unit	3
Discs	4
Speaker Installation	5
Connection.....	6
Remote Control Unit	8
Getting Started	9
Unit Functions	10
Basic Operation	12
Listening to iPod.....	14
Listening to a disc.....	16
Folder Search (MP3/WMA only).....	18
Programmed Playback	18
Shuffle Playback.....	20
Repeat Playback	20
Listening to the DAB Radio	21
Display Setting of the DAB.....	22
Controlling the Various DAB Functions.....	23
Listening to the FM Radio	27
Preset Tuning (FM)	28
RDS.....	29
RDS (PTY Search).....	29
PTY.....	30
Listening to an External Source	30
Setting the Clock.....	31
Setting the Timer	32
Troubleshooting	34
Specifications	35

Before Using the Unit

Read this before operation

- As the unit may become warm during operation, always leave sufficient space around the unit for ventilation. Do not install the subwoofer in a confined space such as a case or similar.
- The voltage supplied to the unit should match the voltage as printed on the rear panel. If you are in any doubt regarding this matter, consult an electrician.
- Choose the installation location of your unit carefully. Avoid placing it in direct sunlight or close to a source of heat. Avoid locations subject to vibrations and excessive dust, heat, cold or moisture.
- Do not place the unit on any other electronic components.
- Do not open the cabinet as this might result in damage to the circuitry or electrical shock. If a foreign object should fall into the unit, contact your dealer or service company as soon as possible.
- When removing the power plug from a wall outlet, always pull directly on the plug. Do not pull on the line cord.
- To keep the laser pickup clean, do not touch it and always close the CD door after each use.
- Do not attempt to clean the unit with chemical solvents as this might damage the finish. Use a clean, dry, lint-free cloth.
- Keep this manual in a safe place for future reference.

CAUTION: DO NOT MOVE THE UNIT DURING PLAYBACK

During playback, the disc rotates at high speeds. Do NOT lift or move the unit during playback. Doing so may damage the disc or the unit.

WHEN MOVING THIS UNIT

When changing places of installation or packing the unit for moving, be sure to remove the disc. Moving this unit with the disc loaded may result in malfunction or other damage.



NXT is a trademark of New Transducers Ltd.

iPod is a trademark of Apple, Inc., registered in the U.S. and other countries.

Discs which can be played on this unit:

- Conventional audio CDs bearing the CD-DA logo on the label:



- Properly finalized CD-R and CD-RW discs
- MP3/WMA CDs

Note:

- Depending on the quality of the disc and/or the condition of the recording, some CD-R/CD-RW discs may not be playable.
- Copy-protected discs and other discs which do not conform to the CD standard may not play back correctly in this player. If you use such discs in this unit, TEAC Corporation and its subsidiaries cannot be responsible for any consequences or guarantee the quality of reproduction. If you experience problems with such non-standard discs, you should contact the producers of the disc.
- Always place the disc on the disc tray with the label side uppermost. (Compact discs can be played or recorded only on one side.)
- To remove a disc from its storage case, press down on the center of the case and lift the disc out, holding it carefully by the edges.



How to remove the disc



How to hold the disc

- Should the disc become dirty, wipe the surface radially (from the center hole outward towards the outer edge) with a soft, dry cloth:



- Never use such chemicals as record sprays, antistatic sprays or fluid, benzine or thinner to clean the discs. Such chemicals will do irreparable damage to the disc's plastic surface.
- Discs should be returned to their cases after use to avoid dust and scratches that could cause the laser pickup to "skip".
- Do not expose discs to direct sunlight or high humidity and temperature for extended periods. Long exposure to high temperatures will warp the disc.
- Do not play any disc that is warped, deformed or damaged. Playing such discs may cause irreparable harm to the playing mechanisms.
- CD-R and CD-RW discs are more sensitive to the effects of heat and ultraviolet rays than ordinary CDs. It is important that they are not stored in a location where direct sunlight will fall on them, and which is away from sources of heat such as radiators or heat-generating electrical devices.

- Use a soft oil-based felt-tipped pen to write the information on the label side. Never use a ball-point or hard-tipped pen, as this may cause damage to the recorded side.
- Never use a stabilizer. Using commercially available CD stabilizers with this unit will damage the mechanisms and cause them to malfunction.
- Do not use irregular shape CDs (octagonal, heart shaped, business card size, etc.). CDs of this sort can damage the unit:

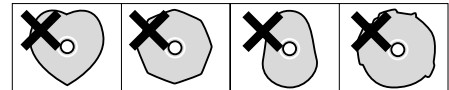

- If you are in any doubt as to the care and handling of a CD-R/CD-RW disc, read the precautions supplied with the disc, or contact the disc manufacturer directly.

MP3 and WMA

- This unit can play MP3 and WMA files recorded on a CD-R, CD-RW.
- File names of MP3 or WMA should be alphanumeric characters. This unit cannot display symbols and full-size or double-byte characters (such as Japanese, Chinese, etc.) correctly. Also, be sure to use the file extension. (".mp3" for MP3 files, ".wma" for WMA files.)
- MP3 files are mono or stereo MPEG-1 Audio Layer 3 format. This unit can play MP3 files with sampling frequency 44.1 kHz or 48 kHz, bit-rate 320 kbps or less.
- This unit can play WMA files with sampling frequency 44.1 kHz, bit-rate 192 kbps or less. WMA means Windows Media Audio.
- Audio encoded at 128 Kbps should sound close to regular audio CD quality. Although this player will play lower bit-rate MP3 tracks, the sound quality becomes noticeably worse at lower bit rates.
- The disc must be finalized in order to play.
- The CD-ROM must be ISO 9660 compatible.
- When more than 255 files are recorded on the disc, the unit might not be able to play it correctly.

Speaker Installation

You can mount the left and right speakers on a wall. Or you can stand the speakers in vertical position.

Precautions

- Be aware that the length of the cables are approximately 2 m. Do not attempt to mount the speakers too far from the subwoofer.
- To hook the speakers on the wall, drill holes into solid wall support, such as wooden frame or concrete wall.
- TEAC supplies the wall mounting brackets as a convenience to the product owner. Consult your local building codes and exercise all necessary caution when mounting these brackets. If you are unsure how to use the supplied brackets, consult with a local tradesmen or building supply expert.

To hook on the wall

1. Fix the brackets on the rear panel of the speakers using the supplied screws.

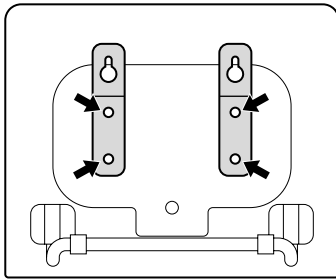

2. Use the supplied guide sheet to mark the exact drilling points on the wall.

3. Drill holes in the wall at the marked points.

4. Screw the commercially available screws into the wall.

Leave about 3 mm space between the screw's head and the wall.

5. Before going on, make connections between the subwoofer and the speakers by referring to pages 6-7.

6. Carefully hang the speakers onto the screws.

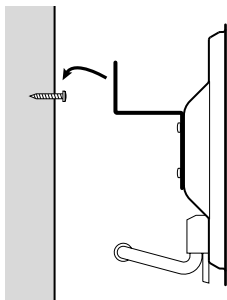

Note:

Ensure that the speaker locks onto the hooks and that the hooks are strong enough to support the weight before removing your hands.

To stand the speakers in the vertical position

1. Remove the stand of the speakers.

Remove the screws of the speaker stand.

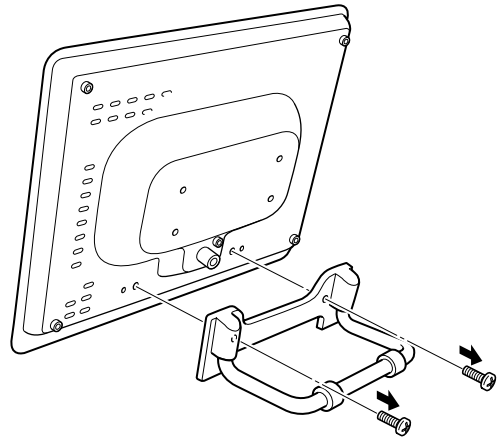

2. Reattach the stand in the vertical position.

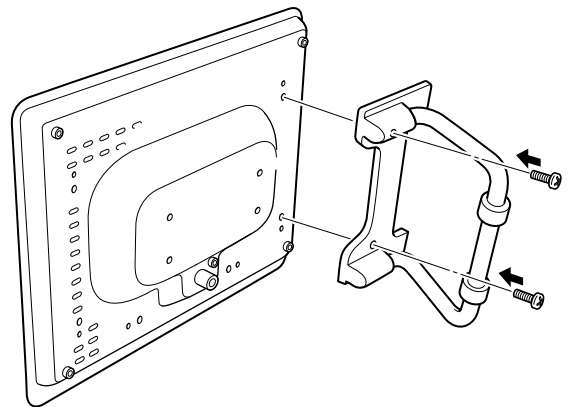

Connection 1

CAUTION:

- Turn off the power of all the equipment before making connections.
- Read instructions of each component you intend to use with this unit.
- Be sure to insert each plug securely. To prevent hum and noise, do not bundle the connection cords with the power cord.

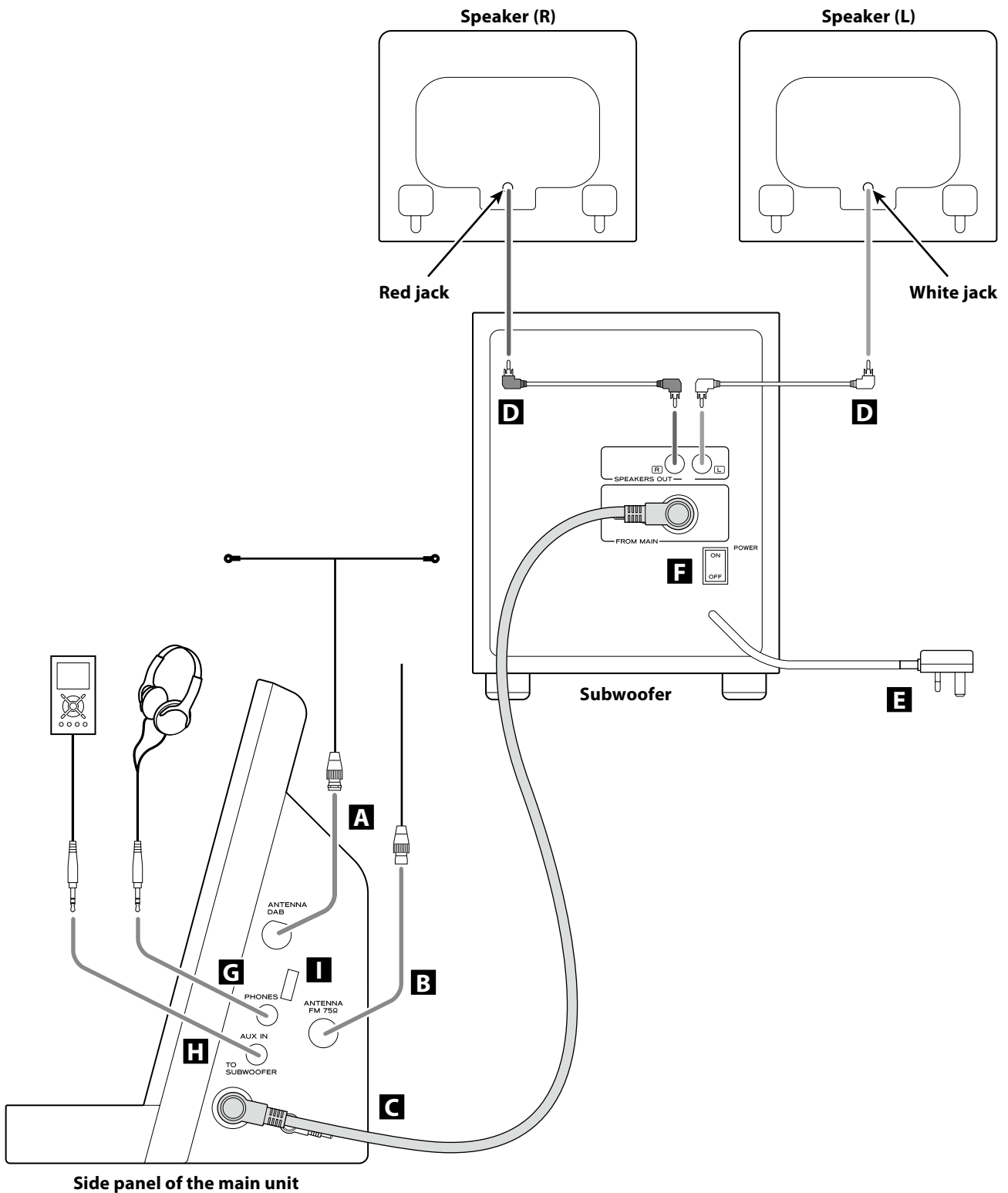

A DAB Indoor Antenna

Connect the supplied T-shape DAB antenna to this jack. Extend the lead vertically and attach it to a window frame or wall with thumbtacks, or the like, where reception is best.

- You can check the antenna adjustment or positioning for the best reception by viewing the signal strength on the display (see page 24).

DAB Outdoor Antenna

In an area where DAB signals are weak, it will be necessary to use an outdoor DAB antenna. There are two main types available.

Dipole:

For use in marginal signal areas. This type of antenna is omnidirectional and should increase the strength of all DAB stations being received.

Multi-element antenna:

Also for use in marginal or poor signal areas. This type of antenna is directional and has high gain. This antenna needs to be pointed at the transmitter you want to listen to.

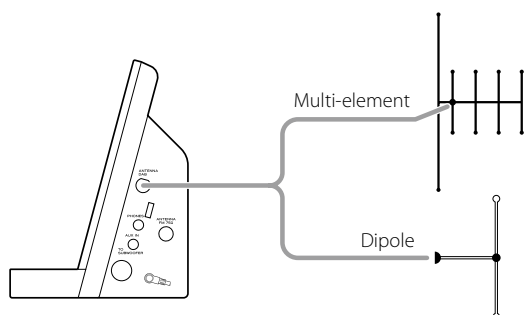

B FM Indoor Antenna

Connect the supplied lead-type FM antenna to this jack. Extend the lead and attach it to a window frame or wall with a thumbtack, where the reception is best.

FM Outdoor Antenna

In an area where FM signals are weak, it will be necessary to use an outdoor FM antenna. Generally, a 3-element antenna will be sufficient; if you live in an area where the FM signals are particularly weak, it may be necessary to use one with 5 or more elements.

- Disconnect the FM indoor antenna when using an outdoor antenna.

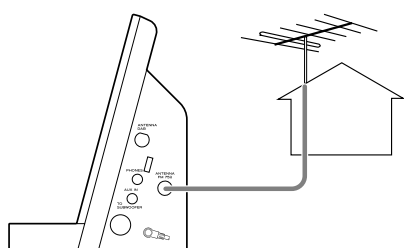

C Subwoofer

Connect the "TO SUBWOOFER" and the "FROM MAIN" sockets using the supplied cable.

- Connect the Connectors in the direction as figured.

D SPEAKERS

Connect the left speaker's plug to L, and the right speaker's plug to R.

- Do not connect anything other than the supplied speakers to these terminals.

E AC Power Cord

Be sure to connect the power cord to an AC outlet which supplies the correct voltage.

Hold the power plug when plugging or unplugging the power cord. Never pull or yank on the power cord.

F POWER switch of the Subwoofer

Use this switch to turn the system on or off.

- If the power switch of the subwoofer turned off, the clock will be reset.

G Headphones

For private listening, first reduce the volume level to minimum. Then insert the plug from your headphones into the PHONES jack, and adjust the volume using the VOLUME buttons. The sound from the speakers is cut off while the headphone jack is inserted.

CAUTION

Always lower the volume level prior to plugging in your headphones. TO AVOID DAMAGING YOUR HEARING - Do not place your headphones on your head until after you have plugged them in.

H AUX IN

You can connect a portable audio player or other audio device to this jack.

Connect the LINE OUT or PHONES jack (audio output jack) of your audio device using the commercially available stereo mini plug cable.

When using the PHONES jack of your mini player, you must adjust the volume of the mini-player or you may hear no sound from your CX-225iDAB.

I Reserved jack

Connection 2

Rear panel of the main unit

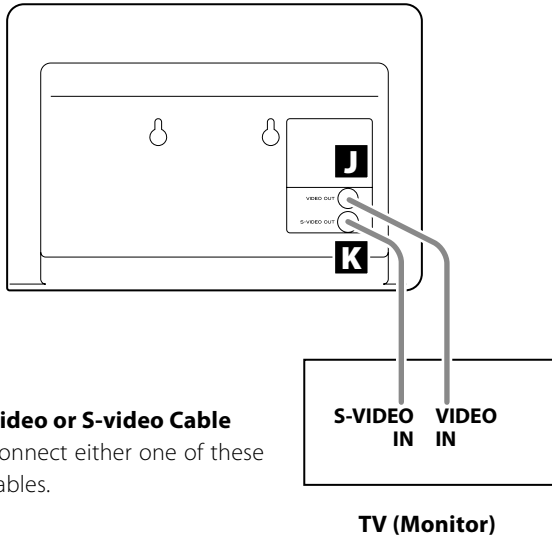

J VIDEO OUT terminal

This terminal outputs video signal from iPod.
Use a commercially available composite video cable to connect the dock to the composite video connector of a television or monitor.

K S-VIDEO OUT terminal

This terminal outputs S-Video signal from iPod.
Use a commercially available S-Video cable to connect the dock to the S-Video input of a suitably equipped television or monitor. Use this connection in preference to a composite video connection.

Remote Control Unit

The provided Remote Control Unit allows the unit to be operated from a distance.

When operating the remote control unit, point it towards the remote sensor on the front panel of the unit.

- Even if the remote control unit is operated within the effective range, remote control operation may be impossible if there are any obstacles between the unit and the remote control.
- If the remote control unit is operated near other products which generate infrared rays, or if other remote control devices using infrared rays are used near the unit, it may operate incorrectly. Conversely, the other products may also operate incorrectly.

Battery Installation

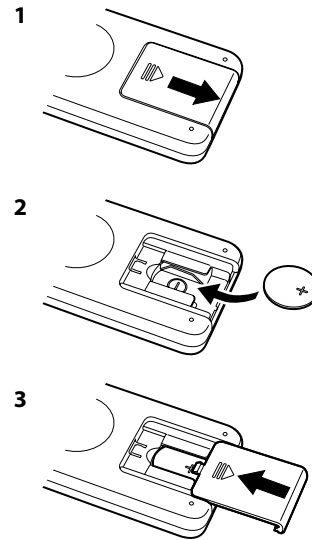

- 1** Remove the battery compartment cover.
- 2** Put in the lithium battery (CR2025, 3V) with the positive side (+) facing outside.
- 3** Close the cover.

Battery Replacement

If the distance required between the remote control unit and main unit decreases, the battery is exhausted. In this case, replace the battery with a new one.

Precautions concerning batteries

Do not heat or disassemble batteries and never dispose of old batteries by throwing them in a fire.

Getting Started

The CX-225iDAB comes mounted with an adapter "60GB (color) + Photo 40/60GB". To play your iPod through the CX-225iDAB, you have first to check if the factory mounted adapter fits your model of iPod. If it does not, you have to replace it with a correct one, as explained below.

1. Remove the adapter from the dock of the CX-225iDAB.

Hold the left and right sides of the adapter and gently pull it up.

2. Choose the dock adapter that fits your iPod mobile digital device.

"nano" for iPod nano 1st and 2nd generations.

"60GB (color) + Photo 40GB/60GB" for Pod with Click Wheel (40 GB) and iPod with color display.

"20GB + U2" for iPod with Click Wheel (20 GB, U2 Special Edition).

- Use a commercially available adapter or a supplied one with your iPod to play other iPods.
- "60GB(color) + Photo 40/60GB" is premounted.

3. Insert the adapter into the dock of the CX-225iDAB.

Fit the front edge of the adapter into the dock, and then press the back edge of the adapter onto the dock until a slight "click" is heard indicating the adapter is inserted correctly.

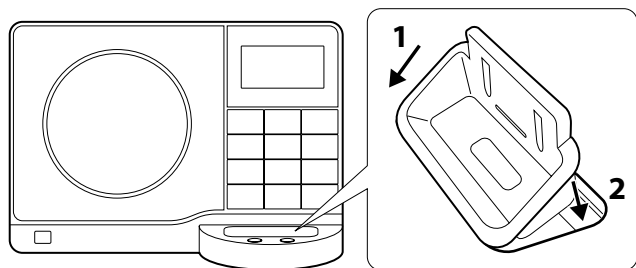

- When you need to remove the adapter, hold the left and right sides of the adapter and gently pull it up.

Caution for iPod video output

- Make the following settings on your iPod's menu to output video to a TV via this system's dock.

In the [Video] menu, select [Video Settings]. Set [TV OUT] to [On] or [Ask].

If you have set [TV OUT] to [Ask], your iPod prompts you each time you play a video to specify whether to output it to a TV.

NOTE:

If you output video to a TV from your iPod, the video is not displayed on the iPod's screen.

iPod touch does not contain this menu. You will have to specify whether to output a video to a TV each time you play it.

Using the alarm on your iPod touch

- If you specify [Slide to power off] on your iPod touch, you cannot use the alarm even if the iPod touch is docked to this system. To use the alarm on your iPod touch, do not select [Slide to power off]. (The screen can be turned off without any problem.)
- If Video is displayed on your iPod touch's screen, you cannot use the alarm even if the iPod touch is docked to this system. To use the alarm on your iPod touch, select any item other than Video.

Compatible iPod Software

In case your iPod will not work with the CX-225iDAB or with the remote control unit, software update may solve the problem. Visit the Apple website and download the latest iPod Software.

<http://www.apple.com/uk/ipod/download/>

Unit Functions

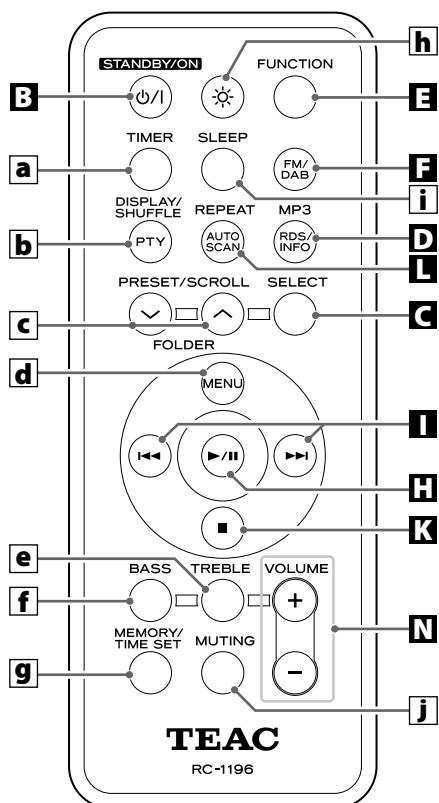
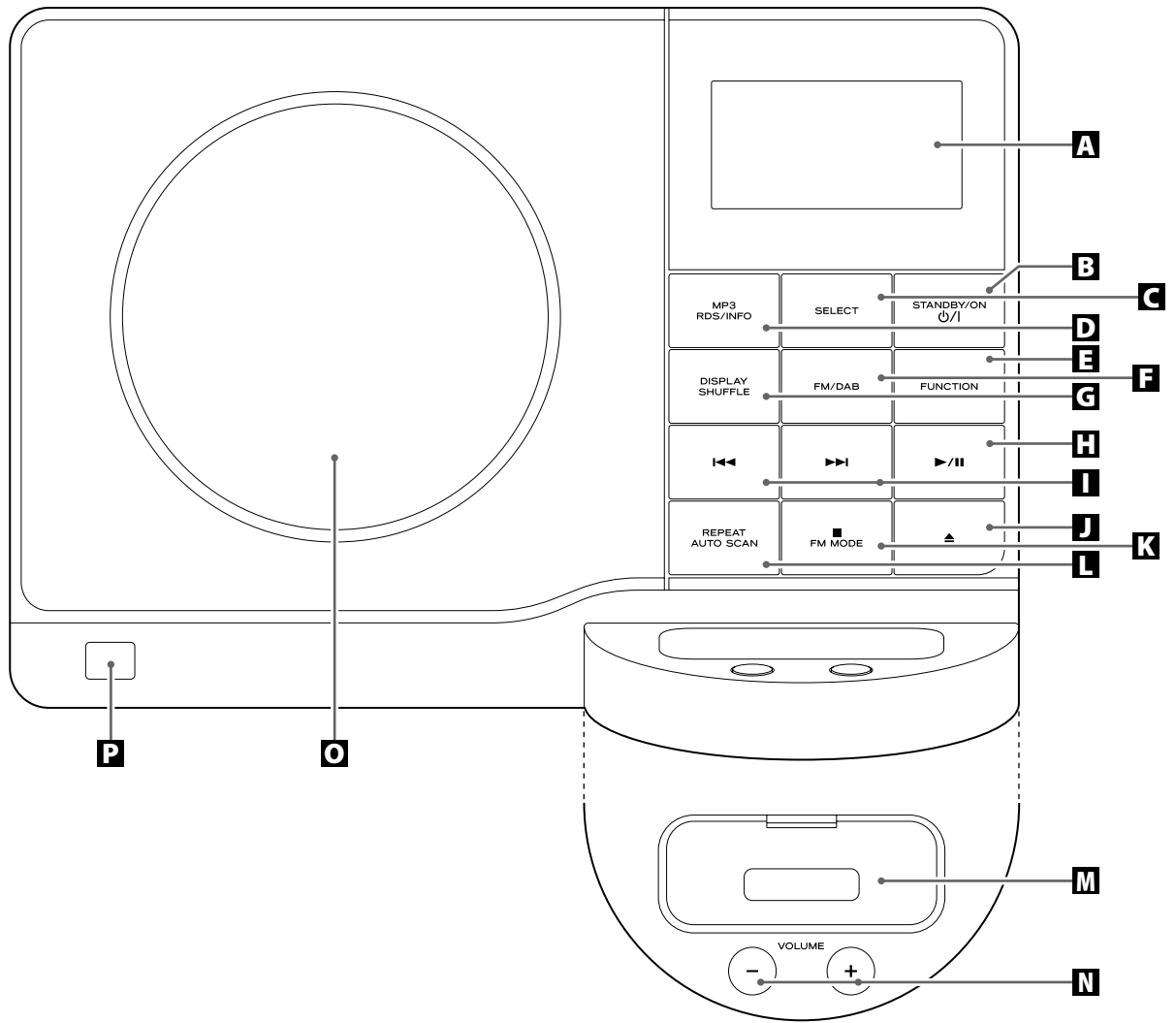

Note:

To simplify explanations, instructions in this manual refer to the names of the buttons and controls on the front panel only. Associated controls on the remote control will also operate similarly.

A display

B STANDBY/ON (⏻/⏻)

Use this button to turn the unit on or standby.
The main unit is powered via the subwoofer. You need to first turn on the subwoofer.

When the main unit is in the standby mode, the power indicator of the Subwoofer is orange.
When the unit is turned on, the indicator turns blue.

C SELECT

This button is equivalent to the Center button on your iPod.
In iPod or DAB mode, use this button to confirm selection in menus.

D MP3/RDS/INFO

During playback of a MP3/WMA disc, use this button to change what information is displayed.
In FM mode, use this button to select an RDS mode.
In DAB mode, use this button to choose the type of information displayed.

E FUNCTION

Use this button to select a source (iPod, CD, Radio or AUX).

F FM/DAB

Use this button to select DAB or FM.

G DISPLAY/SHUFFLE

In DAB mode, use this button to access to the various features.
In iPod or CD mode, use this button to turn on and off the shuffle playback.

H play/pause (▶/⏸)

In iPod or CD mode, use this button to start or pause playback.

I skip/tuning (⏮/⏭)

In iPod or CD mode, momentarily press these buttons to skip tracks. Hold down these buttons to search for a part of a track.
In FM mode, use these buttons to tune in a station.
In Standby mode, these buttons are used to set or adjust the clock and the timer.

J open/close (▲)

In CD mode, use this button to open and close the CD door.

K stop (■)/FM MODE

In CD mode, use this button to stop playback.
In FM mode, use this button to select STEREO or MONO.

- This button does not work in iPod mode.

L REPEAT/AUTO SCAN

In iPod or CD mode, use this button to set the repeat function.
In DAB mode, press this button to activate auto location of all available DAB services. Press once for UK services or, hold for longer than 2 seconds to activate international search.

M Dock connector

Before use, insert an appropriate dock adapter in the dock (see page 9).
Insert an iPod mobile digital device into this dock.

N VOLUME (-, +)

Press the + or the - button to adjust the volume.

O CD door

P Remote Sensor

When operating the remote control unit, point it towards here.

a TIMER

Use this button together with the skip buttons (⏮/⏭) to set the timer.

b DISPLAY/SHUFFLE/PTY

In DAB mode, use this button to access to the various features.
In iPod or CD mode, use this button to turn on and off the shuffle playback.
In FM mode, use this button to start PTY search.

c PRESET/SCROLL/FOLDER (∨, ∧)

In Radio mode, use these buttons to select a preset station.
In iPod mode, use these buttons to scroll up and down the menu.
During playback of a MP3/WMA disc, use these buttons to select a folder in the disc.

d MENU

This button is equivalent to the MENU button on your iPod.
In iPod mode, use this button to go back to the previous menu.

e TREBLE

Use this button and the VOLUME buttons to adjust the level of high frequency sound range.

f BASS

Use this button and the VOLUME buttons to adjust the level of low frequency sound range.

g MEMORY/TIME SET

In CD mode, use this button to program tracks or files.
In Radio mode, use this button to preset stations.
This button is also used for clock adjustment.

h dimmer (※)

Use this button to change the brightness of the front panel display.

i SLEEP

Use this button to set sleep timer.

j MUTING

Use this button to mute the sound.

Basic Operation

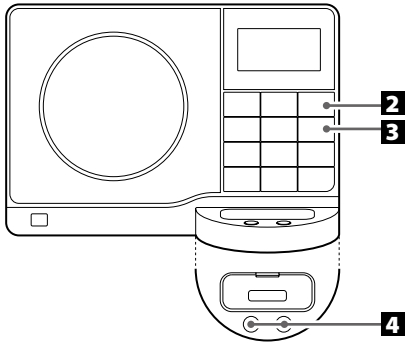

1 Turn on the subwoofer.

(Rear panel of the subwoofer)

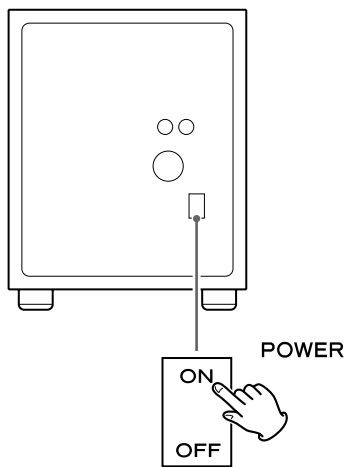

2 Press the STANDBY/ON button (⏻) on the main unit.

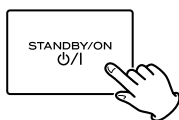

3 Select a source by pressing the FUNCTION button.

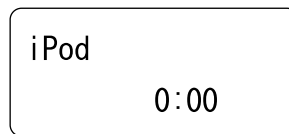
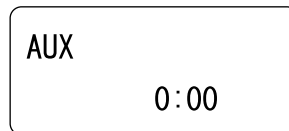
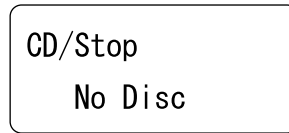
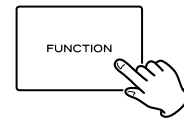

- To listen to an external source connected to the AUX IN jack, select AUX.
- In AUX mode, the display always shows the clock.
- If no iPod is inserted into the dock when iPod mode is selected, "Not connected" is displayed. When the iPod is inserted into the dock, the display shows the clock.
- If you press and hold the TIME SET button for 2 seconds in CD or Radio mode, the clock will be displayed for a few seconds.

4 Play the source and adjust the volume using the VOLUME buttons.

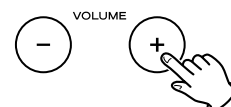

Muting

To mute the sound temporarily, press the MUTING button. Press the MUTING button again to restore the sound.

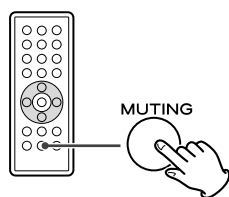

- While muting is engaged, "Muting" blinks on the display.
- If you change the volume during the muting, the muting will be canceled.
- When the function is changed during the muting, the muting will be cancelled.

Headphones

For private listening, first reduce the volume level to minimum. Then insert the plug from your headphones into the PHONES jack, and adjust the volume using the VOLUME buttons. The sound from the speakers is cut off while the headphone jack is inserted.

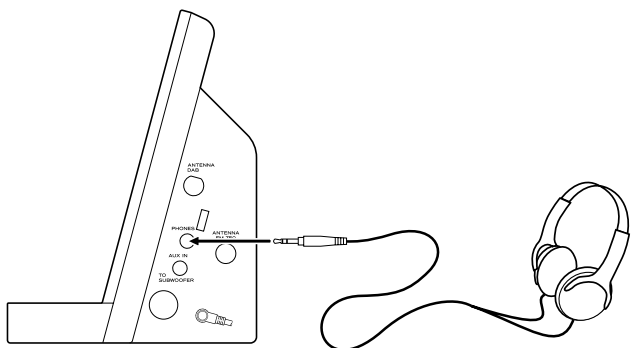

CAUTION

Always lower the volume level prior to plugging in your headphones. TO AVOID DAMAGING YOUR HEARING - Do not place your headphones on your head until after you have plugged them in.

Sleep Timer

Repeatedly pressing the SLEEP button permits setting an interval (from 90 down to 10 minutes) after which you want the unit to automatically turn off and shift into Standby mode.

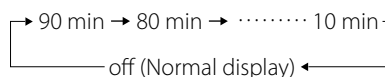
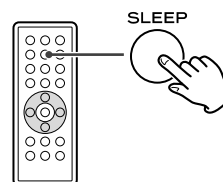

Dimmer

You can dim the display using the dimmer button (☼).

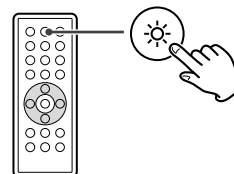

- This function will be cancelled when the STANDBY/ON button is pressed.

Tone Control

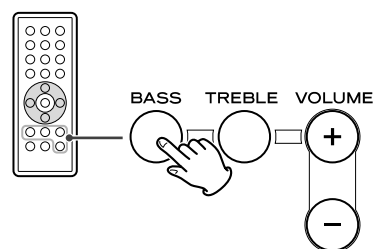

1. Press the BASS or TREBLE button.

To adjust the level of low frequency sound range, press the BASS button.

To adjust the level of high frequency sound range, press the TREBLE button.

2. Within 2 seconds, press the VOLUME buttons to change the setting.

The level can be adjusted from -4 to +4.

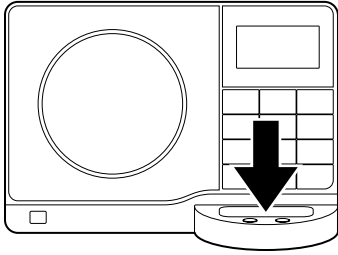

Insert the iPod into the dock of the CX-225iDAB.

The CX-225iDAB will automatically turn to iPod mode, and start playback from the iPod's music list.

- If the iPod is inserted into the dock during the CX-225iDAB in standby mode, the CX-225iDAB will automatically turn on and start playback of the iPod.
- Make sure to use an appropriate dock adapter (see "Getting Started" on page 9).
- The battery of the iPod is recharged to the full when the iPod is docked and the CX-225iDAB is on.
- When headphones are plugged into the iPod, sound comes from both the speakers of the CX-225iDAB and the headphones.
- The stop button (■) does not work in iPod mode.
- In standby mode, CX-225iDAB can not recharge iPod because of minimised power consumption to meet the regulation of IEA. If you need to recharge iPod, please turn on the unit.

To select iPod mode

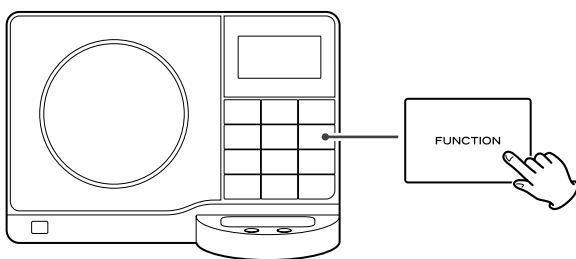

Select "iPod" using the FUNCTION button. If an iPod is already docked, playback will start.

In iPod mode, press the play/pause button (▶/||) to start or pause playback.

To suspend playback temporarily (pause mode)

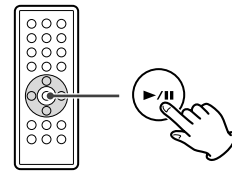

Press the play/pause button (▶/||) during playback. Playback stops at the current position. To resume playback, press the play/pause button (▶/||) again.

To skip to the next or a previous song

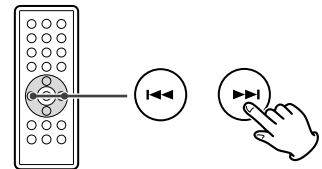

During playback, press the skip button (◀◀ or ▶▶) repeatedly until the desired song is found. The selected song will be played from the beginning.

- When the ◀◀ button is pressed during playback, the song being played will be played from the beginning. To return to the beginning of the previous song, press the ◀◀ button twice.

Search for a part of a song

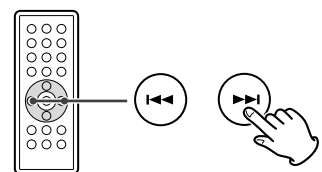

During playback, hold down the skip button (◀◀ or ▶▶) for more than 2 seconds and release it when the part you want to listen to is found.

To go back to the previous menu

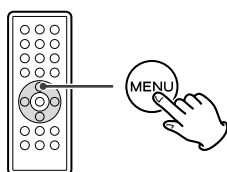

Press the MENU button to go back to the previous menu.
This button is equivalent to the MENU button on your iPod.

Select the menu item

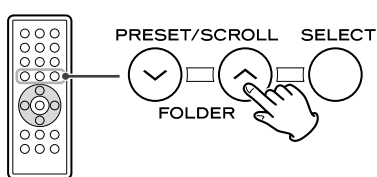

Press the PRESET/SCROLL buttons (∨/∧) to scroll to the menu item you want, and then press the SELECT button.

To activate the shuffle mode

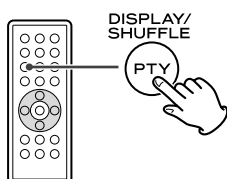

During playback, press the SHUFFLE button to change the shuffle mode.
Each time the SHUFFLE button is pressed, the SHUFFLE setting of iPod is changed as follows:

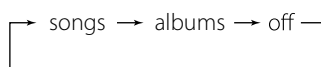

If iPod is set to shuffle songs or albums, the shuffle icon (⌘) appears in the iPod's display.

To activate the repeat mode

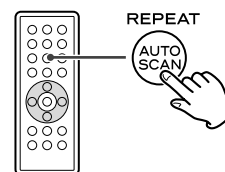

During playback, press the REPEAT button to change the repeat mode.

Each time the REPEAT button is pressed, the REPEAT setting of iPod is changed as follows:

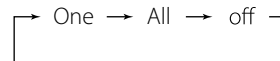

If the iPod is set to repeat one song, the Repeat One icon (🔁) appears in the iPod's display.

If the iPod is set to repeat all songs, the Repeat icon (🔁) appears in the iPod's display.

Listening to a disc

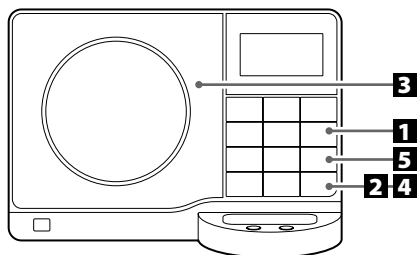

1 Press the **FUNCTION** button to select "CD".

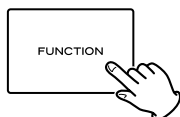

2 Press the **open/close button** (▲).

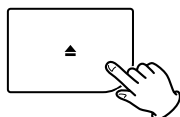

3 Put a disc onto the center spindle of the player with the label side facing you.

Press the disc onto the spindle until a slight "click" is heard indicating the disc is mounted correctly.

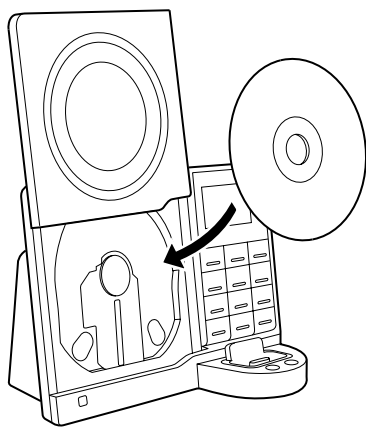

- Never put more than one disc onto the spindle at a time.
- Ensure that the disc is correctly mounted on the spindle and locked in place.

4 Press the **open/close button** (▲) to close the CD door.

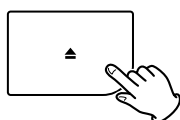

- It takes a few seconds for the unit to load the disc. No buttons will work during loading. Wait until the total number of the tracks and the total play time of the disc are displayed.
- When no disc is loaded in the CD player, "No Disc" is displayed.

Audio CD

The total number of the tracks and total play time of the disc are displayed.

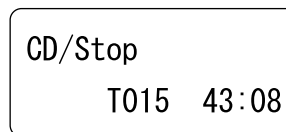

MP3/WMA disc

The total number of files of the disc is displayed. "MP3" is displayed even if the playback file is WMA.

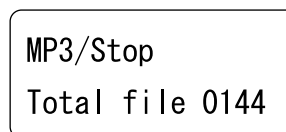

5 Press the **play/pause button** (▶/||) to start playback.

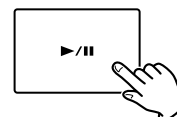

Disc playback starts from the first track/file.

Audio CD

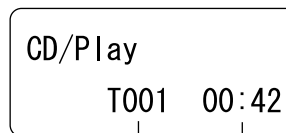

current track number elapsed time of the current track

MP3/WMA disc

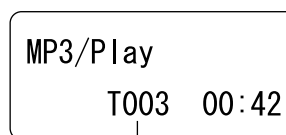

current file number

- If there are MP3/WMA files recorded out of folders, they are automatically put in the "001" (root) folder. If there is no MP3/WMA file out of folders, the first folder is numbered as "001". Playback starts from the first file of the "001" folder.
- If there are folders that has no MP3/WMA file, this unit skips them.
- When the playback of all the tracks/files has finished, the unit stops automatically.

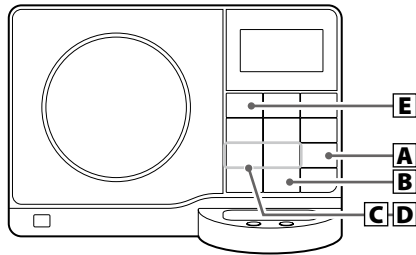

A To suspend playback temporarily (pause mode)

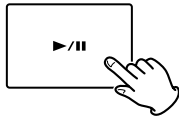

Press the play/pause button (▶/||) during playback. Playback stops at the current position and "Pause" is displayed. To resume playback, press the play/pause button (▶/||) again.

B To stop playback

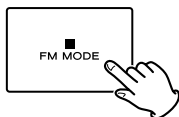

Press the stop button (■) to stop playback.

C To skip to the next or a previous track

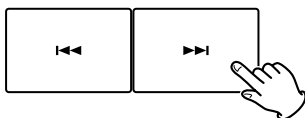

During playback, press the skip button (◀◀ or ▶▶) repeatedly until the desired track is found. The selected track will be played from the beginning.

In the stop mode, press the skip button (◀◀ or ▶▶) repeatedly until the track you want to listen to is found. Press the play/pause button (▶/||) to start playback from the selected track.

- When the ◀◀ button is pressed during playback, the track being played will be played from the beginning. To return to the beginning of the previous track, press the ◀◀ button twice.
- During programmed playback, the next or previous track in the program is played.

D Search for a part of a track

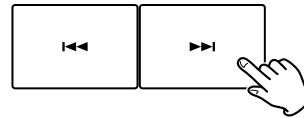

During playback, hold down the skip button (◀◀ or ▶▶) and release it when the part you want to listen to is found. During searching, "Search" is displayed.

E To display MP3/WMA information

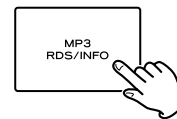

During playback of an MP3/WMA disc, each time the MP3 button is pressed. The information about the current track is changed as follows:

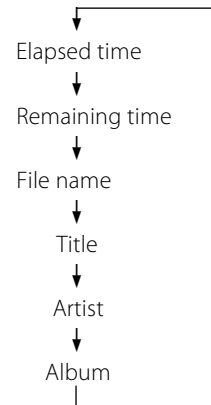

- During playback of an MP3/WMA disc, press the MP3 button for more than 1 second. The information about the current track is displayed scrolling. To cancel scrolling, press the MP3 button again.
- UNKNOWN appears when the unit cannot read the information.

Folder Search (MP3/WMA only)

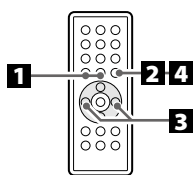

While in stop or playback mode, you can select and playback a desired folder or a desired file in a folder.

1 Press the FOLDER buttons (v/^) to select a folder.

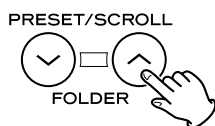

The order of the folders may be changed depending on the hierarchy of the folders.

2 Press the SELECT button.

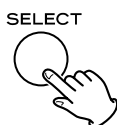

3 If you want to select a file, press the skip button (I◀◀ or ▶▶I).

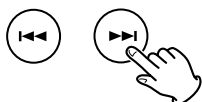

- You can select a file in the selected folder.

4 Press the SELECT button.

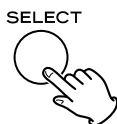

Playback starts from the selected file.

Programmed Playback

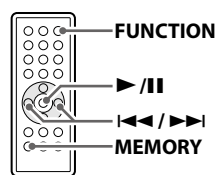

Up to 32 tracks can be programmed in the desired order.

1 Press the FUNCTION button to select "CD".

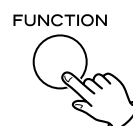

2 Press the MEMORY button.

"Mem" is displayed.

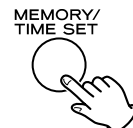

CD

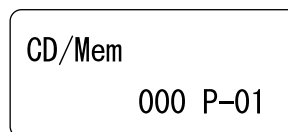

MP3

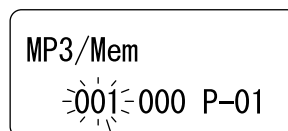

folder number is flashing

- To cancel the program mode, press the stop button (■).

3 Press the skip button (I◀◀ or ▶▶I) repeatedly to select a folder of a MP3 disc, then press the MEMORY button.

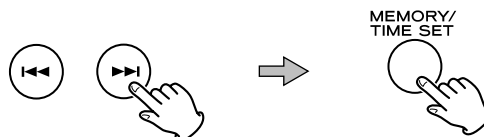

MP3

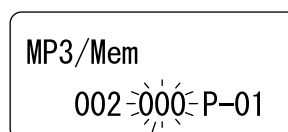

file number is flashing

- MP3/WMA files recorded out of folders are in the "001" (ROOT) folder.
- Skip this step when playing a CD.

- 4** Press the skip button (I◀◀ or ▶▶I) repeatedly to select a track, then press the MEMORY button.

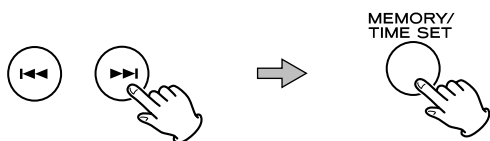

CD

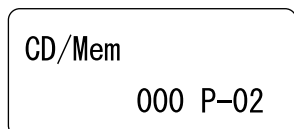

MP3

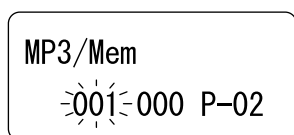

The track/file is programmed, and "P-02" is displayed.

- Repeat steps **3** and **4** to program more tracks/files.
- You can program up to 32 tracks.

- 5** When the selection of track numbers is completed, press the play/pause button (▶/||) to start program playback.

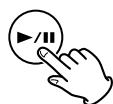

- When the playback of all the programmed tracks/files has finished, or if you press the stop button (■), the "Mem" indicator will go off and the program mode will be cancelled. Still the program is retained in memory. You can return to the programmed playback by pressing the MEMORY button and the play/pause button (▶/||).
- Shuffle function does not work during programmed playback.
- When there is a folder which contains the files other than MP3 and WMA (such as JPEG files) is included in a disc, the program may not function correctly. Program the MP3 and WMA files only.

To check the programmed order

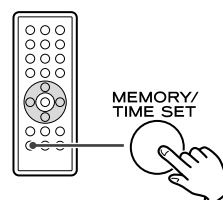

In the stop mode, press the MEMORY button repeatedly. The track number and program number will be shown on the display.

To add a track to the end of the program

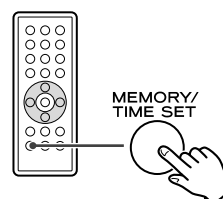

In the stop mode, press the MEMORY button repeatedly until "00" or "000" appears on the display. Select a track number using the skip button (I◀◀ or ▶▶I) and then press the MEMORY button. The track is added to the end of the program.

To overwrite the program

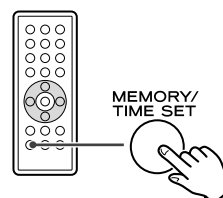

In the stop mode, press the MEMORY button repeatedly until the program number to be changed appears on the display. Select a new track number using the skip button (I◀◀ or ▶▶I) and then press the MEMORY button.

To clear program

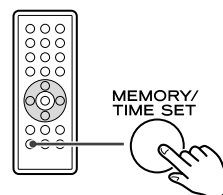

If one of the following buttons is pressed, the programmed contents will be cleared:

open/close (▲), FUNCTION, FM/DAB, STANDBY/ON

- If the unit is disconnected from the power supply, the programmed contents will be cleared.

Shuffle Playback

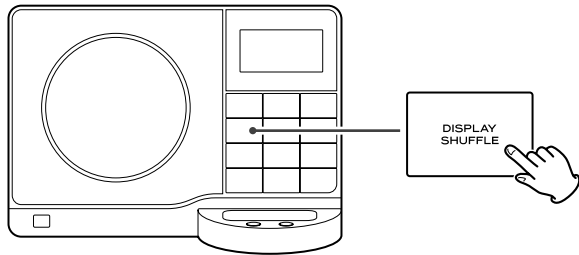

The tracks can be played randomly. Press the SHUFFLE button during playback or when in the stop mode. "Shuffle" will then appear in the display.

- If you press the ►► button during shuffle playback, next track will be randomly selected and played.
If you press the ◀◀ button, next track will be randomly selected and played.
A track cannot be replayed during shuffle playback.
- Shuffle playback does not work during programmed playback.
- If one of the following buttons is pressed, shuffle mode will be cancelled:

SHUFFLE, stop (■), FUNCTION, FM/DAB
STANDBY/ON, open/close (▲)

Repeat Playback

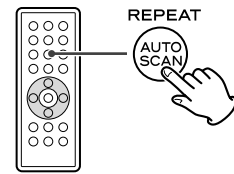

Every time the REPEAT button is pressed, the mode is changed as follows:

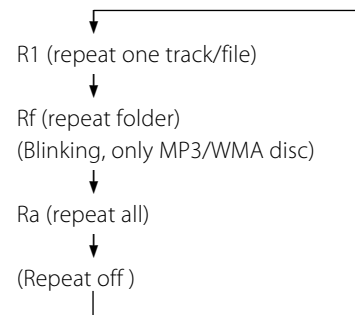

- When the stop button (■) is pressed the repeat mode is cancelled.
- During the programmed playback, "Rf" cannot be selected.

Repeat one track/file (R1)

The track/file being played will be played repeatedly. If you select another track/file in R1 mode, the track/file you selected will be played repeatedly.

If you select R1 mode in the stop mode and select a track/file, the selected track/file will be played repeatedly.

Repeat folder (Rf) (Only MP3/WMA disc)

All the tracks or files in the folder will be played repeatedly.
If you select another folder in Rf mode, the tracks/files in the folder will be played repeatedly.

Repeat all (Ra)

All the tracks or files will be played repeatedly.

- In the program mode, the programmed contents are played repeatedly.

Listening to the DAB Radio

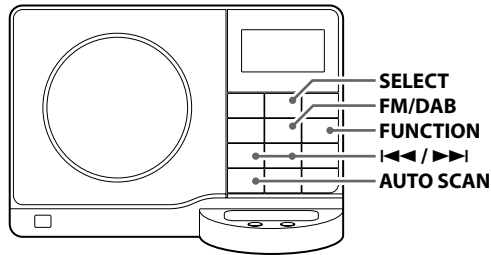

Auto Tuning

1 Press the **FUNCTION** button to select "Radio".

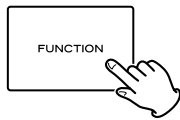

2 Press the **FM/DAB** button to switch to DAB mode.

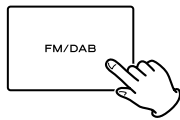

When the unit is switched to DAB mode for the first time, the auto tuning process will start automatically. (Autoscan local: 11B to 12D)

- If you want to search stations internationally, press and hold the **AUTO SCAN** button for longer than 2 seconds to activate "Autoscan full" (5A to 13F).

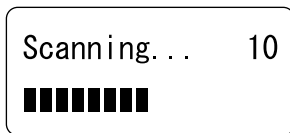

If no broadcast services are found, "No stations available" is displayed and the unit will automatically enter to Manual tune mode.

In this case, every time the skip button (<=> or >=>) is pressed, the mode is changed as follows:

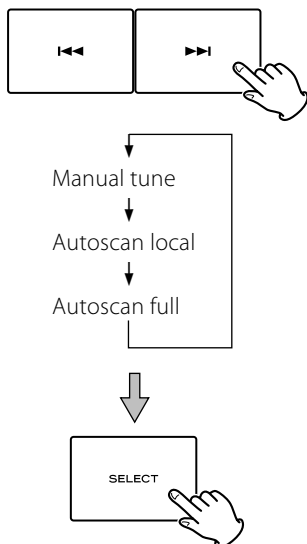

If the Autoscan local or full mode is selected, the unit will start the scanning process.

3 When the scanning process has finished, press the skip button (<=> or >=>) to select the station you want to listen to.

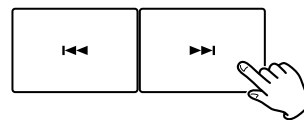

current tuning station

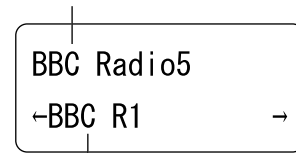

select the station you want to listen to

When the Manual tune is selected.

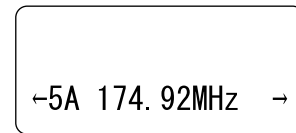

4 Within 7 seconds press the **SELECT** button.

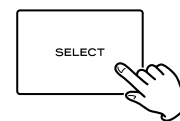

- If you do not press the **SELECT** button within 7 seconds, the display will return to the current tuning station.
- If you move the unit to a new area or you want to check to see if there are new channels available in your area, you can scan to find new channels automatically.

5 Press the **AUTO SCAN** button.

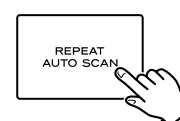

Display Setting of the DAB

You can choose the type of information displayed in the second line of the display while listening to DAB.

Each time the INFO button is pressed, the information is displayed as follows.

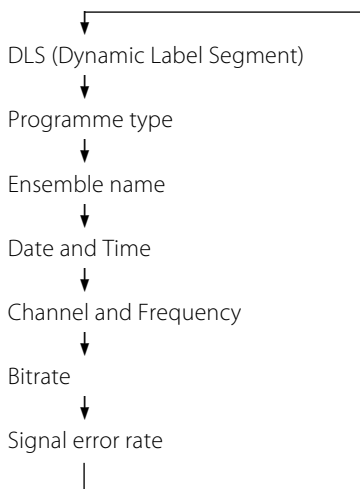
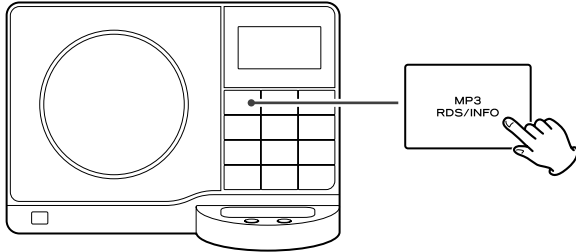

DLS

The Dynamic Label Segment (DLS) is the scrolling text label supplied by the radio station. It may be information on music titles or details regarding the programme or station.



Programme type

This is a description of the type of broadcast supplied by the radio station such as Pop, Rock or Classical music.

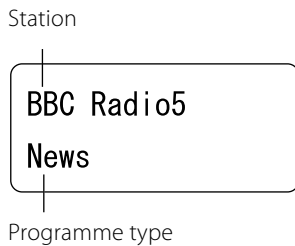

Ensemble name

This displays the name of the Ensemble that is broadcasting the programme.

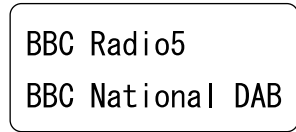

Date and time

This displays the current date and time, which is supplied by the radio station and should always be accurate.

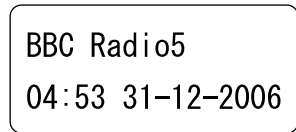

Channel and frequency

This displays the channel and frequency of the current playing broadcast.

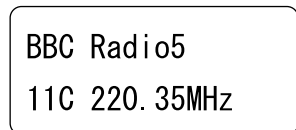

Bitrate

The bitrate and sound mode of the current receiving broadcast is displayed.

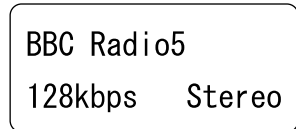

Signal error rate

This displays the digital bit error rate (0-99) of the currently tuned channel. The lower the figure the better the quality of the received broadcast.

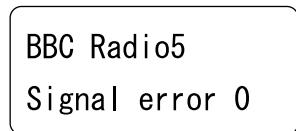

Controlling the Various DAB Functions 1

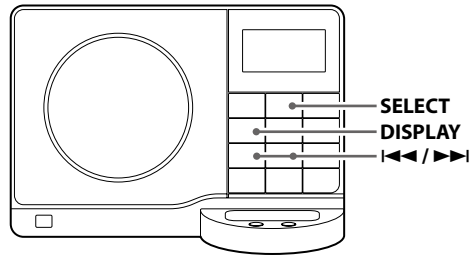

In DAB mode, each time the DISPLAY button is pressed, the Function Control is changed as follows.

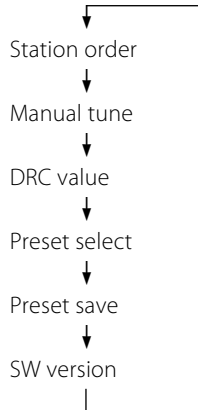

Station order

Use station order to set the order in which stations are listed. There are four orders: Favourite, Alphanumeric, Active and Prune.

1 While listening to a DAB broadcast press the DISPLAY button.

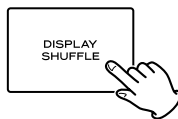

2 Select "Station order" using the skip button (left or right arrow).

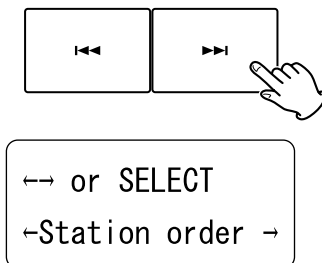

3 Press the SELECT button.

The current option is displayed in the first line of the display.

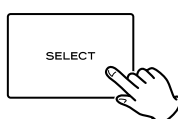

4 Select the desired option in the second line of the display using the skip button (left or right arrow).

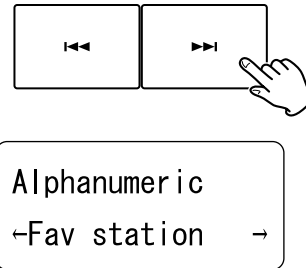

5 Press the SELECT button.

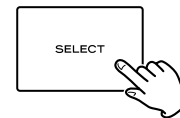

Fav station (Favourite station)

As you tune in stations and listen to them the unit will memorize the top ten stations you listen to and list them at the top of the service list. A Favourite station in the service list has "♥" displayed after the station name.

Alphanumeric

This is the default order. Stations are listed by name with numbers first and then alphabetically by letters in the station's name.

Active station

This option will list active stations at the top of the service list and stations that are in the list but have no service in your area to be listed last in the service list.

Prune stations

This option will list active stations and remove any stations that are in the list but have no service in your area from the service list. Those invalid stations in the service list have a question mark (?) displayed in front of the station name.

Select Prune stations and press the SELECT button. All stations that have a question mark will be deleted from the service list.

♥ → presets

This option takes your top ten Favourite stations and assigns them to preset numbers 1–10. This option is only available after "Fav Station" option has been turned on. See above.

Controlling the Various DAB Functions 2

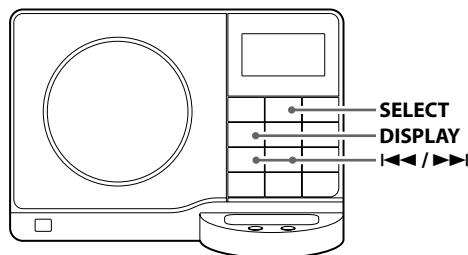

Manual tune

This option allows you to manually tune in a channel and view a continuously updated display of the strength of the signal. This may be useful when adjusting or positioning an antenna for better reception.

- 1** While listening to a DAB broadcast press the DISPLAY button.

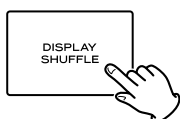

- 2** Select "Manual tune" using the skip button (◀◀ or ▶▶).

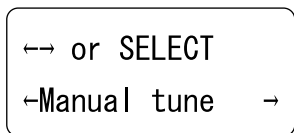
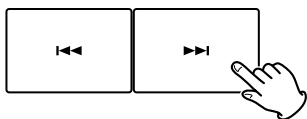

- 3** Press the SELECT button.

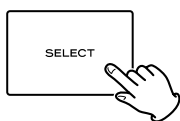

- 4** Press the skip button (◀◀ or ▶▶) to select the station you want to listen to.

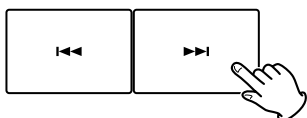

- 5** Press the SELECT button when the channel you wish to tune in is displayed in the second line of the display.

The current signal strength and the required level indicator are displayed.

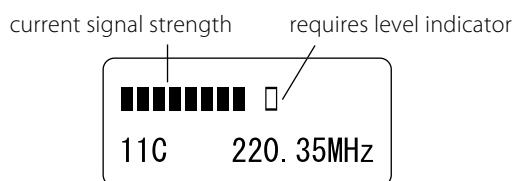
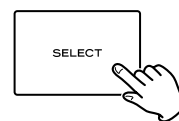

- The signal strength should meet this required level indicator to tune in the station.

- 6** While viewing the indicator, adjust or reposition the antenna until the best reception is indicated.

- 7** Press the SELECT button to cancel Manual tune and resume normal reception.

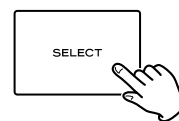

DRC value

This option sets the Dynamic Range Control (DRC) value to be applied to received broadcasts. DRC is used to reduce the range between high and low volumes of audio and is sometimes applied at the broadcast source. Pop music may have a high value of DRC applied, appropriate for constantly high listening levels, while classical music broadcasts may have no DRC applied to allow the listener to hear the full dynamic range of the source volume.

There are three values of DRC you can apply.

- 0 : None
- 1/2 : Medium
- 1 : Maximum

- 1** While listening to a DAB broadcast press the DISPLAY button.

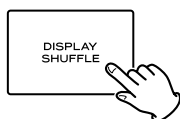

- 2** Select "DRC value" using the skip button (I◀◀ or ▶▶I).

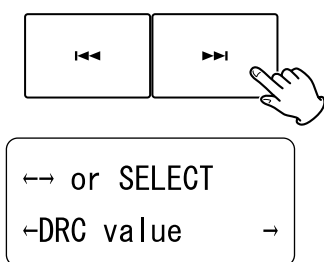

- 3** Press the SELECT button.

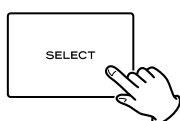

- 4** Select the desired level of DRC in the second line of the display using the skip button (I◀◀ or ▶▶I).

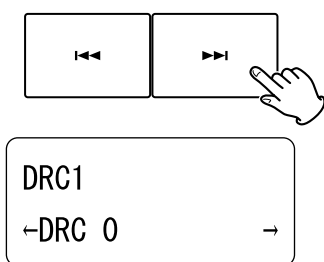

- 5** Press the SELECT button.

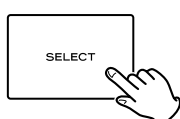

Preset select

Use this option to select the DAB preset station.

- 1** While listening to a DAB broadcast press the DISPLAY button.

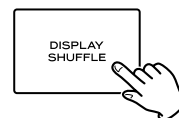

- 2** Select "Preset select" using the skip button (I◀◀ or ▶▶I).

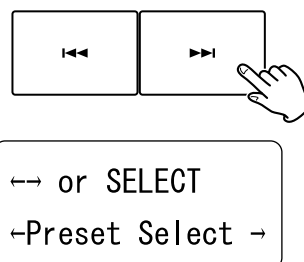

- 3** Press the SELECT button.

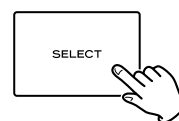

currently tuned station.

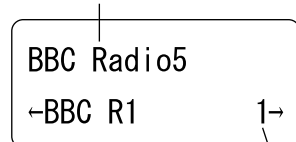

preset No.

- 4** Select the desired preset station in the second line of the display using the skip button (I◀◀ or ▶▶I).

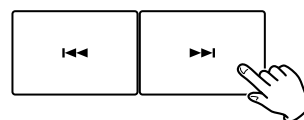

- 5** Press the SELECT button.

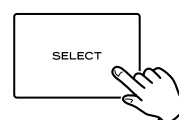

Controlling the Various DAB Functions 3

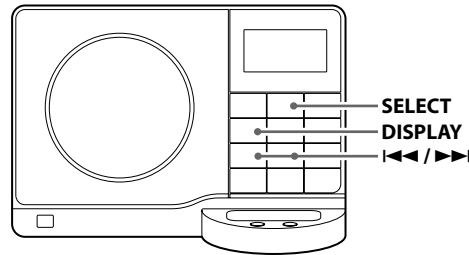

Preset save

Use this option to save up to 30 DAB stations to preset into memory.

- 1 While listening to the DAB station you want to save press the DISPLAY button.

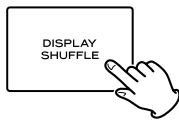

- 2 Select "Preset Save" using the skip button (I◀◀ or ▶▶I).

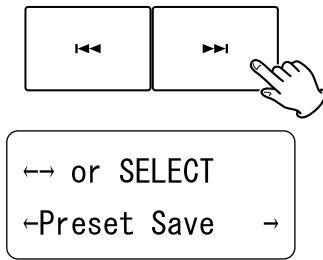

- 3 Press the SELECT button.

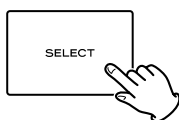

- 4 Select the preset number to save the station using the skip button (I◀◀ or ▶▶I).

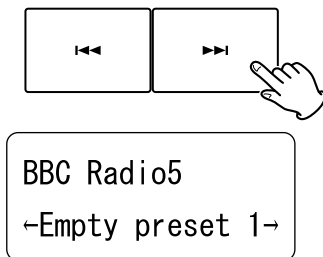

- 5 Press the SELECT button.

The station is saved to the selected number.

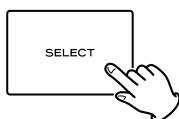

Sw version (Software version)

This option shows the version number of the installed software. This is for information only and no adjustment is available.

- 1 While listening to a DAB broadcast press the DISPLAY button.

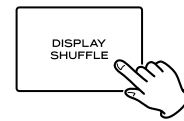

- 2 Select "Sw version" using the skip button (I◀◀ or ▶▶I).

The version number of the installed software is displayed.

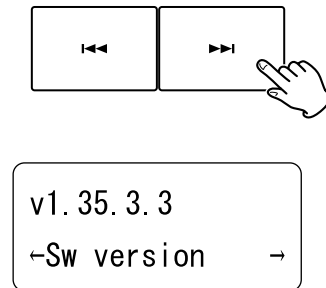

If you want to initialize the DAB settings:

Press and hold the DISPLAY button for longer than 2 seconds to display "Press SELECT to confirm reset". Press the SELECT button.

- All settings are cleared and the auto tuning process will start automatically.

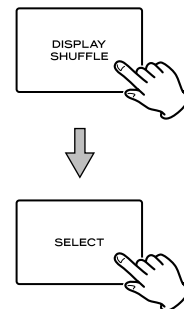

Listening to the FM Radio

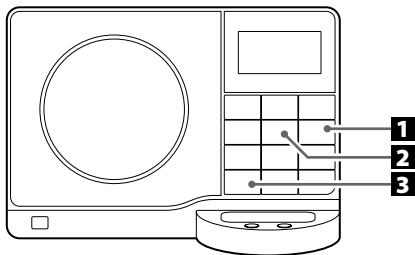

1 Press the FUNCTION button to select "Radio".

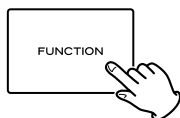

- You can also use the FM/DAB button to select "Radio".

2 Press the FM/DAB button to switch to FM.

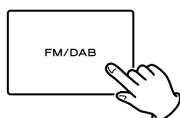

3 Select the station you want to listen to (auto selection).

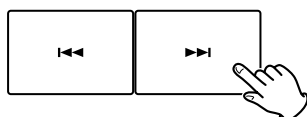

Hold down the TUNING/PRESET button (◀◀ or ▶▶) for more than 0.5 second.

When a station is found, the tuning process will stop automatically.

If you want to stop the tuning process, press the TUNING/PRESET button (◀◀ or ▶▶).

Selecting stations which cannot be tuned automatically (manual selection)

When the TUNING/PRESET button (◀◀ or ▶▶) is pressed momentarily (0.5 second or less), the frequency changes by a fixed step.

Press the TUNING button repeatedly until the station you want to listen to is found.

FM MODE button

Pressing this button alternates between STEREO mode and MONO mode.

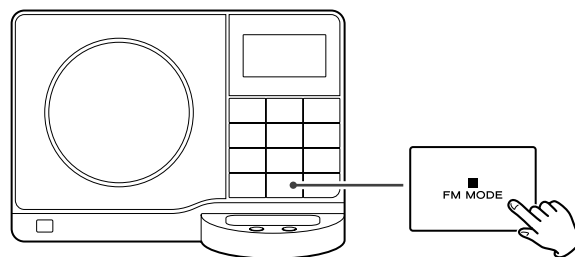

STEREO (Auto)

FM stereo broadcasts are received in stereo and the "St" appears in the display.

- If the sound is distorted the signal is not strong enough for good stereo reception. In this case, it automatically changes to Mono mode.

Mono

To compensate for weak FM stereo reception, select this mode. "Mo" is displayed. Reception will now be forced to monaural, reducing unwanted noise.

If the reception is poor

Extend and rotate the DAB/FM antenna until you receive the stations clearly.

In an area where FM signals are weak, it will be necessary to use an outdoor FM antenna (see page 7).

Preset Tuning (FM)

You can store FM stations into preset channels 1 to 10 respectively.

1 Tune in a station you want to listen to (see steps **1** to **3** of page 27).

2 Press the MEMORY button.

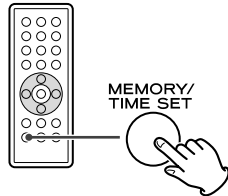

3 Within 3 seconds, select a preset channel to store station using the PRESET buttons of the remote control unit.

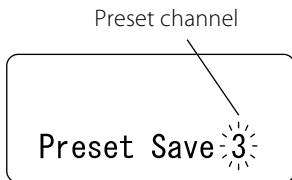
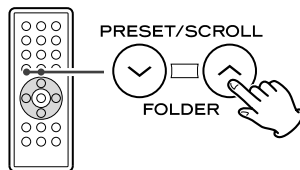

4 Within 5 seconds, press the MEMORY button.

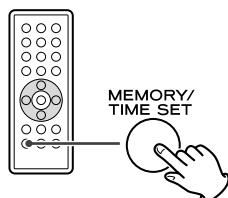

The station is stored.

To store more stations, repeat steps **1** to **4**.

How to select preset stations

1 Press the FM/DAB button to select FM.

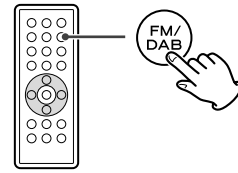

2 Press the PRESET button repeatedly until the desired preset station is found.

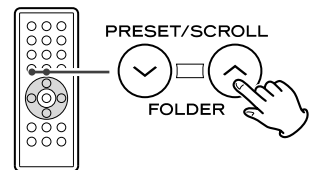

RDS

The Radio Data System (RDS) is a broadcasting service which allows stations to send additional information along with the regular radio programme signal.

RDS works on the FM waveband in Europe only.

1 Tune in an FM station (see steps 1 to 3 of page 27).

2 Press the RDS button.

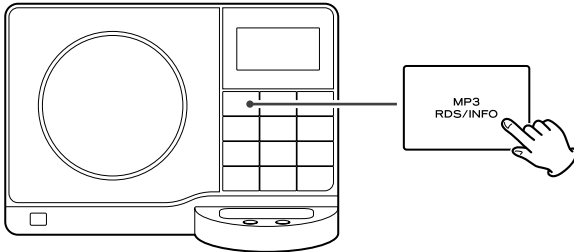

Each time the RDS button is pressed briefly, the RDS mode is changed as follows:

PS (Programme Service name)

When you select PS, "PS" will blink for about 4 seconds and then PS or a station's name will be displayed. If there is no PS data, the frequency will be displayed.

PTY (Programme Type)

When you select PTY, "PTY" will blink for about 4 seconds and then the programme type will be displayed.

RT (Radio Text)

When you select RT, "RT" will blink for about 4 seconds and then the news of stations composed of up to 64 symbols will be displayed.

If there is no CT/PTY/RT data, RDS mode will be switched to PS mode automatically.

The clock setting will be automatically adjusted according to the CT data. If you tune in an RDS station broadcasting incorrect CT data, the clock might be wrongly adjusted, and that may eventually affect the timer operation.

No matter which RDS mode is selected, the unit receives CT data and adjusts the clock.

To turn on or off the CT mode, press and hold the RDS button for more than 10 seconds.

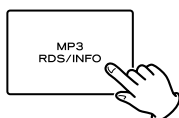

RDS (PTY Search)

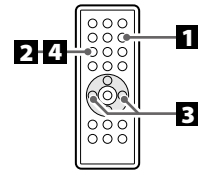

A station can be searched by this function.

1 Select FM by pressing the FM/DAB button.



2 Press the PTY button.

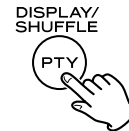

"PTY SEL" appears on the display.

3 Select the desired PTY programme using the skip button (◀◀ or ▶▶).

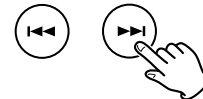

You can select from 31 kinds.

4 Press the PTY button.



Searching will start.

- When the programme that you have selected is found, searching will stop and the programme type will be displayed.
- If the same program type is not found during PTY Search, it will stop at the beginning frequency.
- If you want to stop searching, press the PTY button.

- NEWS : brief announcements, events, public opinion, reports, actual situations.
- AFFAIRS : a kind of suggestion including practical announcements other than news, documents, discussion, analysis and so on.
- INFO : daily information or reference such as weather forecast, consumer guide, medical assistance and so on.
- SPORT : sports related programs.
- EDUCATE : educational and cultural information.
- DRAMA : all kinds of radio concert and serial drama.
- CULTURE : all aspects of national or local culture including religious events, philosophy, social science, language, theatre, and so on.
- SCIENCE : programs on natural science and technology.
- VARIED : popular programs such as quiz, entertainment, private interview, comedy, satire and so on.
- POP M : program on commercial, practical and popular songs, and sale volume of discs, etc.
- ROCK M : practical modern music generally composed and played by young musicians.
- M.O.R.M : popular music usually lasting for less than 5 minutes.
- LIGHT M : classical music, instrumental music, chorus, and light music favored by non-professionals.
- CLASSICS : orchestra including great operas, symphony, chamber music and so on.
- OTHER M : other music styles (Rhythm & Blues, Reggae, etc.)
- WEATHER : weather reports, forecast
- FINANCE : financial reports, commerce, trading
- CHILDREN : children's programs
- SOCIAL : social affairs
- RELIGION : religious programs
- PHONE IN : program in which the public expresses its view by phone.
- TRAVEL : travel reports
- LEISURE : programs concerning recreational activities
- JAZZ : jazz music
- COUNTRY : country music
- NATION M : national music
- OLDIES : music from the so-called golden of popular music
- FOLK M : folk music
- DOCUMENT: documentaries
- TEST
- ALARM : a program notifying an emergency or a natural disaste

1 Connect the output jack of your audio device (ex: the PHONES jack of a portable audio player) to the AUX IN jack of the CX-225iDAB using the commercially available stereo mini plug cable.

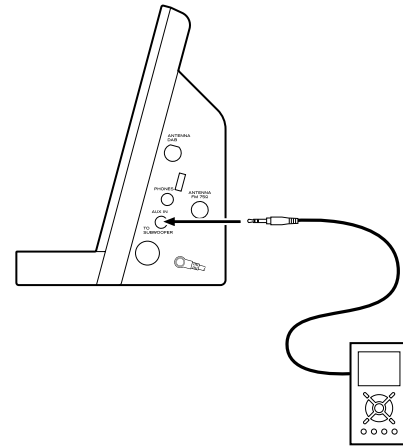

2 Press the FUNCTION button to select "AUX".

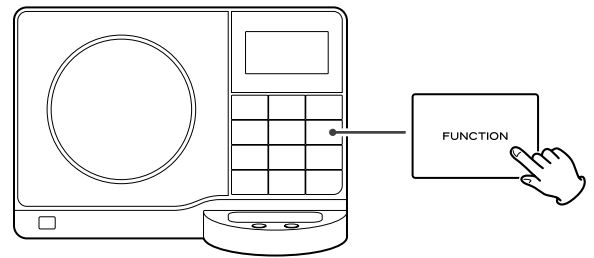

3 Play the source, and adjust the volume using the VOLUME buttons of the CX-225iDAB and the audio device.

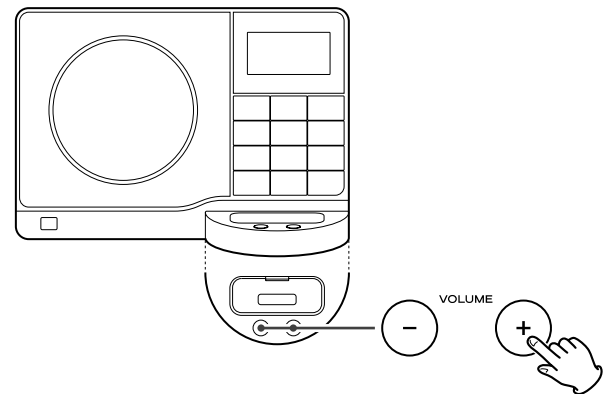

When using the PHONES jack of your player, you must adjust the volume of the player or you may hear no sound from your CX-225iDAB.

Setting the Clock

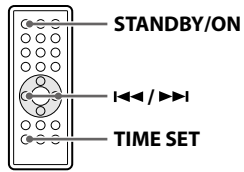

If the power switch of the subwoofer turned off, the clock will be reset.

1 If the unit is on, press the STANDBY/ON button (⏻/⏻) to turn it standby.



2 Press and hold down the TIME SET button.

The "hour" value blinks.

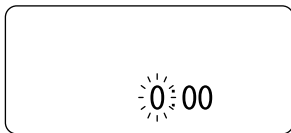

- If no button is pressed for 10 seconds, the time setting mode will be cancelled.

3 Press the skip button (I<</>>I) to set the current hour.

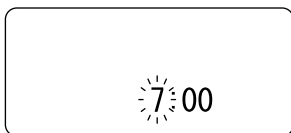
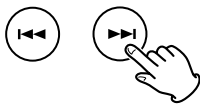

4 Press the TIME SET button.

The "minute" value blinks.

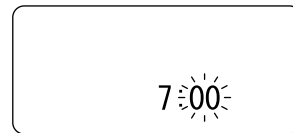

5 Press the skip button (I<</>>I) to set the current minute.

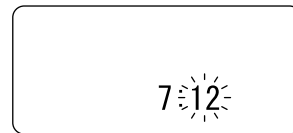
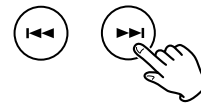

6 Press the TIME SET button.

The clock starts.



Setting the Timer

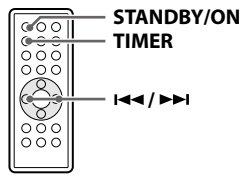

- The unit can be programmed to turn on and off at a specified time.
- Adjust the clock before setting the timer.

1 Press and hold the **TIMER** button until “TimerOn” appears on the display.



The “hour” value starts flashing.

- When no button is pressed for 60 seconds, the timer setting mode will be cancelled.

2 Press the skip button (I◀◀/▶▶I) to set the start time (hour), and then press the **TIMER** button.

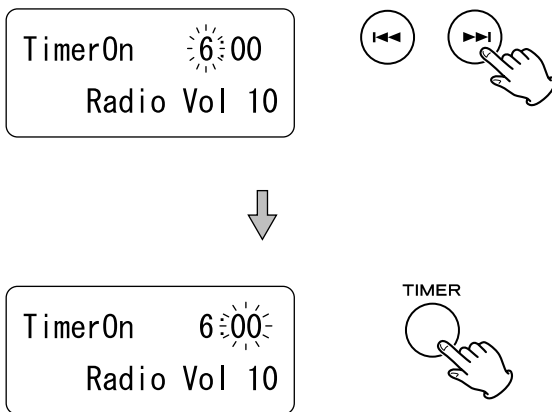

The “minutes” value starts flashing.

3 Press the skip button (I◀◀/▶▶I) to set the start time (minute), and then press the **TIMER** button.

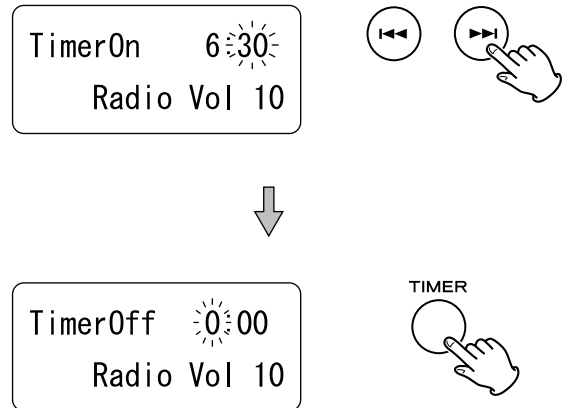

“TimerOff” appears on the display and the “hour” value starts flashing.

4 Press the skip button (I◀◀/▶▶I) to set the stop time (minute), and then press the **TIMER** button.

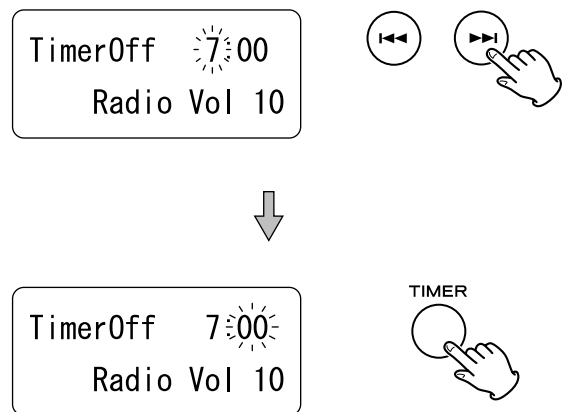

The “minutes” value starts flashing.

5 Press the skip button (I◀◀/▶▶I) to set the stop time (hour), and then press the **TIMER** button.

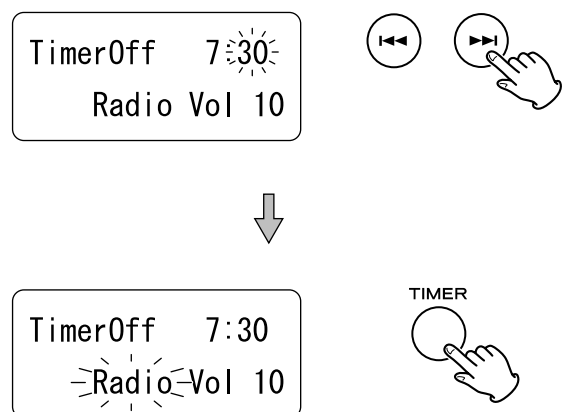

6 Press the SKIP button (I◀◀/▶▶I) to select a source (Radio, CD or iPod), and then press the TIMER button.

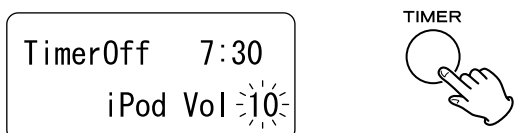
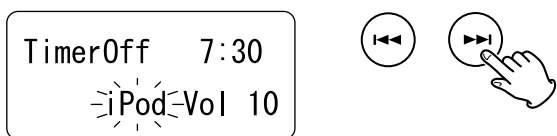

- "AUX" cannot be selected.

7 Press the SKIP button (I◀◀/▶▶I) to set the volume, and then press the TIMER button.

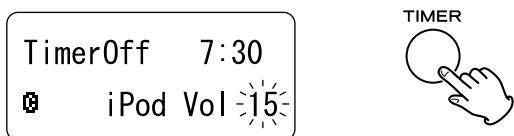
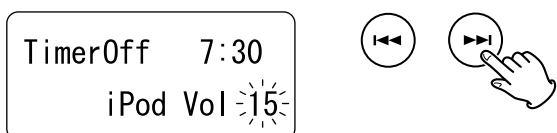

Setting the timer is now completed and the timer is turned on. Your timer on/off setting is displayed in order.

8 Prepare the source.

- If you selected "Radio" in step **6**, tune in a station.
- If you selected "CD" in step **6**, set a disc.
- If you selected "iPod" in step **6**, insert an iPod.

9 Press the STANDBY/ON button to turn the unit off (standby).



The clock and the TIMER indicator are displayed. The unit will turn on and standby at the specified time every day.

Do not forget to turn the unit into standby mode, or the timer will not work.

If the power switch of the subwoofer turned off, the clock will be reset.

Do not turn off the subwoofer, or the timer will not work

- Playback volume will gradually increase up to your set volume when the unit is turned on by timer.
- If the source is set to "iPod" but no iPod is set, the unit will turn on into Radio mode.
- If the source is set to "CD" but no disc is set, the unit will turn on into Radio mode.
- When the source is set to "Radio" and the unit turns on, it will tune in to the station you selected last time.

To turn on or off the timer

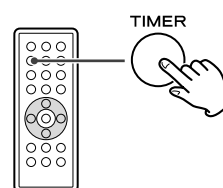

Press the TIMER button once, and during the timer settings being displayed press again to turn it on or off.

If you have problems with your system, look through this chart and see if you can solve the problem yourself before calling your dealer or TEAC service center.

General

No power

- ➔ Check the connection to the AC power supply. Check and make sure the AC source is not a switched outlet and that, if it is, the switch is turned on. Make sure there is power to the AC outlet by plugging another item such as a lamp or fan into the outlet.

No sound from speakers.

- ➔ Select the source by pressing the FUNCTION button.
- ➔ Check the connection to the speakers.
- ➔ Adjust the volume.
- ➔ Pull out the headphone's plug from the PHONES jack.
- ➔ If "Muting" is blinking, press the MUTING button.

The sound is noisy.

- ➔ The unit is too close to a TV or similar appliances. Install the unit apart from them, or turn them off.

Remote control does not work.

- ➔ Press the STANDBY/ON switch to turn the unit on.
- ➔ When the battery has run out, put in a new one.
- ➔ Use remote control unit within the range (5 m) and point at the front panel.
- ➔ Clear obstacles between the remote control unit and the main unit.
- ➔ If a strong light is near the unit, turn it off.

CD Player

Will not play.

- ➔ Load a disc with the playback side facing away.
- ➔ If the disc is dirty, clean the surface of the disc.
- ➔ A blank disc has been loaded. Load a prerecorded disc.
- ➔ Depending on the disc, etc. it may not be possible to play back CD-R/RW discs. Try again with another disc.
- ➔ You cannot play back unfinalized CD-R/RW discs. Finalize such a disc in a CD recorder and try again.

Sound skips.

- ➔ Place the unit on a stable place to avoid vibration and shock.
- ➔ If the disc is dirty, clean the surface of the disc.
- ➔ Do not use scratched, damaged or warped discs.

iPod Player

Cannot insert the iPod.

- ➔ Check the dock adapter.
- ➔ Remove dust or obstacles from the dock connector of the CX-225iDAB and the iPod, and insert the iPod again.

Will not play.

- ➔ Remove the iPod from the dock, wait a few seconds, and insert it again.
- ➔ Software update may solve the problem. Visit the Apple website and download the latest iPod Software.

Radio

Cannot listen to any station, or signal is too weak.

- ➔ Tune in the station properly.
- ➔ Rotate the FM/DAB antenna for the best reception position.

Though the FM broadcast is stereo, it sounds monaural.

- ➔ Switch the FM mode to STEREO using the FM MODE button.

"NO stations available" appears on the display.

- ➔ Check that antenna is stretched.
- ➔ Ensure that DAB coverage exists in your area.

Cannot access secondary services.

- ➔ Secondary service is part-time programme transmitted as a side channel of the primary station. When you want to listen to a secondary station, check its broadcasting schedule.

Display goes out or displays "Station off-air".

- ➔ This may occur if a broadcaster changes the label of a service or removes a label whilst you are listening to it. The CX-225iDAB will try to retune to this station, or alternatively follow the procedure for auto tune on page 21.

Cannot listen to the selected station.

- ➔ Ensure you have pressed the SELECT button when you want to listen to your selection. The station you are currently listening to will be displayed on the first line of the display, as you scroll through the station order list the second line will show other station options. Press the SELECT button to activate your selection.

A burbling sound is heard on some stations.

- ➔ DAB like other digital media is good at producing quality audio from a low level signal. However, if this signal level is too low, a "burbling" sound can sometimes be heard. To reduce this, try repositioning your antenna to gain maximum signal strength.

If normal operation cannot be recovered, unplug the power cord from the outlet and plug it again.

Beware of condensation

When the unit (or a disc) is moved from a cold to a warm place, or used after a sudden temperature change, there is a danger of condensation; vapor in the air could condense on the internal mechanism, making correct operation erratic or impossible. To prevent this, or if this occurs, leave the unit for one or two hours with the power turned on. The unit will stabilize at the temperature of its surroundings.

Maintenance

If the surface of the unit gets dirty, wipe with a soft cloth or use diluted mild liquid soap. Never spray liquid directly on this unit. Apply your cleaner to your cleaning cloth and wipe gently. Be sure to remove any excess completely. Do not use thinner, benzene or alcohol as they may damage the surface of the unit. Allow the surface of the unit to dry completely before using.

Specifications

AMPLIFIER section

Output Power (L+R) 5 W + 5 W
Output Power (Subwoofer)..... 15 W
Input Sensitivity..... 500 mV
Frequency Response 50 to 20,000 Hz

Radio Section (FM)

Frequency Range 87.50 to 108.00 MHz (50 kHz step)
Sensitivity (S/N30dB) 10 dB μ V/m

Radio Section (DAB)

Frequency Range Band III: 5A to 13F
(174.928 MHz to 239.200 MHz)

CD PLAYER Section

Frequency Response 20 to 20,000 Hz (\pm 1 dB)
Signal-to-Noise Ratio 55 dB
Wow and Flutter Unmeasurable

SPEAKER

Type..... Full range flat type
Impedance 4 ohms

SUBWOOFER

Impedance 8 ohms

GENERAL

Power Requirements 230 V AC, 50 Hz
Power Consumption 74 W
Dimension (W x H x D)
Main Unit..... 247 x 169.5 x 135 mm
L & R Speakers 210 x 169.5 x 85 mm
Subwoofer..... 170 x 220 x 325 mm
Weight (Net)
Main Unit..... 1.3 kg
L & R Speakers 0.6 kg each
Subwoofer..... 4.6 kg

Standard Accessories

Remote control unit (RC-1196) x 1
Battery for remote control unit (CR2025) x 1
Subwoofer cable x 1
Speaker cable x 2
DAB antenna x 1
FM antenna x 1

Dock adapter x 3
(adapter "60GB (color) + Photo 40GB/60GB" premounted)

Wall mount bracket x 4
Screw x 8
Guide sheet for wall mounting x 2

Owner's manual x 1
Quick guide for connection x 1
Warranty card x 1

- Design and specifications are subject to change without notice.
- Weight and dimensions are approximate.
- Illustrations may differ slightly from production models.

Information for Users on Collection and Disposal of Old Equipment and used Batteries

These symbols on the products, packaging, and/or accompanying documents mean that used electrical and electronic products and batteries should not be mixed with general household waste. For proper treatment, recovery and recycling of old products and used batteries, please take them to applicable collection points, in accordance with your national legislation and the Directives 2002/96/EC and 2006/66/EC.

By disposing of these products and batteries correctly, you will help to save valuable resources and prevent any potential negative effects on human health and the environment which could otherwise arise from inappropriate waste handling.

For more information about collection and recycling of old products and batteries, please contact your local municipality, your waste disposal service or the point of sale where you purchased the items.

[Information on Disposal in other Countries outside the European Union]

These symbols are only valid in the European Union. If you wish to discard these items, please contact your local authorities or dealer and ask for the correct method of disposal.

Note for the battery symbol (bottom two symbol examples):

This symbol might be used in combination with a chemical symbol. In this case it complies with the requirement set by the Directive for the chemical involved.



TEAC

TEAC CORPORATION	1-47 Ochiai, Tama-shi, Tokyo 206-8530, Japan Phone: (042) 356-9156
TEAC AMERICA, INC.	7733 Telegraph Road, Montebello, California 90640 Phone: (323) 726-0303
TEAC CANADA LTD.	5939 Wallace Street, Mississauga, Ontario L4Z 1Z8, Canada Phone: (905) 890-8008
TEAC MEXICO, S.A. De C.V	Rio Churubusco 364, Colonia Del Carmen, Delegación Coyoacán, CP 04100, México DF, México Phone: (5255)5010-6000
TEAC UK LIMITED	Unit 19 & 20, The Courtyards, Hatters Lane, Watford, Hertfordshire, WD18 8TE, U.K. Phone: (0845) 130-2511
TEAC EUROPE GmbH	Bahnstrasse 12, 65205 Wiesbaden-Erbenheim, Germany Phone: 0611-71580

This appliance has a serial number located on the rear panel. Please record the model number and serial number and retain them for your records.

Model number _____ Serial number _____

0908-MA-1393A